

Conventional Machine

The best sales in the world



TP-202

Main Features:

- ▶ Light, compact design
- ▶ Easy operation, simple maintenance
- ▶ Hinged stainless top plate
- ▶ Mechanical outside tension control
- ▶ Rigid castors with brake
- ▶ Automatic motor stop to save energy
- ▶ Reliable P.C. Board electric control
- ▶ Affordable for every budget, total value more than competing brands
- ▶ Proven quality with over 80,000 sets sold

Options

- ▶ Enclosed frame model TP-201, fixed height
- ▶ Adjustable table height from 760 mm to 930 mm

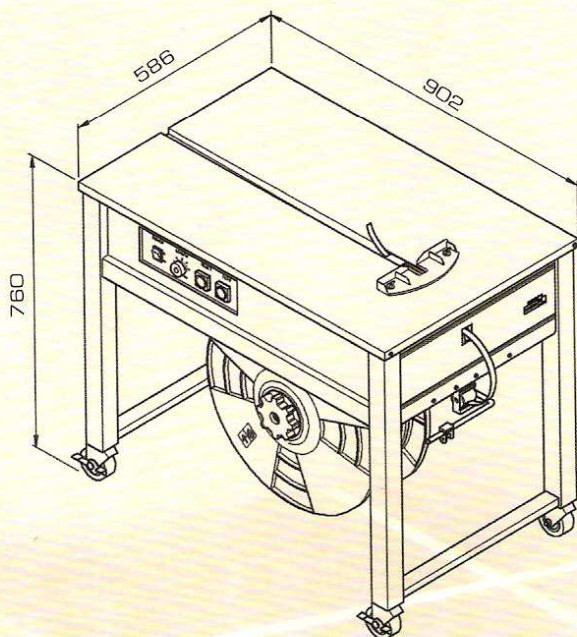

TP-202 TECHNICAL DATA

Strap Width: 6 mm-15.5 mm

Strap Tension: 15-45 kg

Net Weight: 85 kg

Power: 110V, 220V, 230V 50/60Hz 1PH