

New Generation Machine

Someday all semi strappers will be made in this way

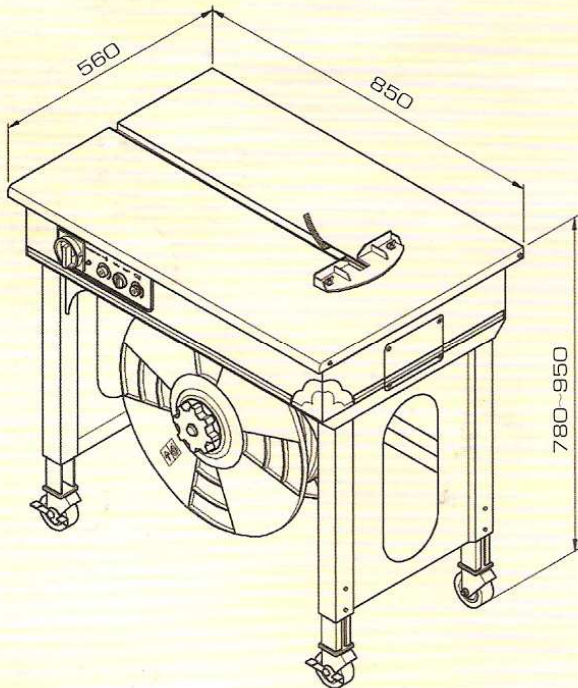

Options

- ▶ Enclosed frame model TP-501
- ▶ Conversion kit for small packages
- ▶ Digital readout for tension and feed settings

GENESIS TP-502

Main Features:

- ▶ **Compact Mechanical Control Head**
With 30% less moving parts than conventional machines substantially reduces maintenance issues. There are no belts, chains or pulleys. Extremely low noise sealing head.
- ▶ **Electronic Tension Control**
Adjustment for wider strap tension (8-45 kg) can be easily done on the front control panel.
- ▶ **Sensor Controlled Heater**
The faster 24V heating mechanism is sensor controlled assuring you of consistent and high efficiency seals.
- ▶ **Large Main Switch**
The lockable CE rated large main power switch increases safe operation of the machine.
- ▶ **Adjustable Table Height**
The table height is adjustable to any height between 780 mm and 950 mm.

TP-502 TECHNICAL DATA

Strap Width: 5 mm-13 mm
Strap Tension: 8-45 kg
Adjustable Table Height: 780 mm-950 mm
Net Weight: 70 kg
Power: 110V, 220V, 230V 50/60Hz IPH