

Side-Seal Automatic Strapping Machine

Tauris



TP-601Y

- Painted steel frame
- Ideal for dirty strapping environment, such as sawmill plants, brick and tile industries

Option

- ▶ Without adjustable roller table (TP-601Y-XT)

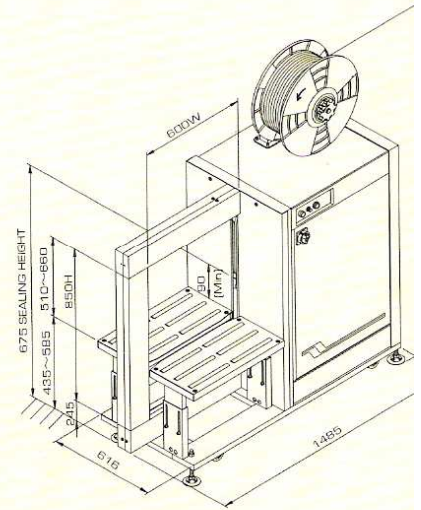

TP-601YS

- Stainless steel frame SUS 304 and selected parts in stainless steel
- Ideal for moist strapping environment, such as meat, fish, poultry and agricultural processing plants

Option

- ▶ Without adjustable roller table (TP-601YS-XT)



TP-601YM

- Stainless steel frame SUS 304 with rust resistant and corrosion retardant parts.
- Ideal for moist and harsh strapping environments, exclusively designed for marine food industry.
- Waterproof design to protect the machine from water and wash down spray
- Special protection for the electric control unit to ensure highest safety

Option

- ▶ Without adjustable roller table (TP-601YM-XT)

Main Features:

- ▶ Automatic side-seal strapping machine offers reliability and high performance
- ▶ Auto strap feeding
- ▶ Electronic tension control
- ▶ Auto strap ejector
- ▶ Larger arch sizes are available for large packages
- ▶ Easy adjustable roller table height (minimum height: 435 mm)

Arch Sizes:

H \ W	400	600	800	1000
650				
850		Ⓢ		
1050				
1250				

- Standard size: 600 mm(W) x 850 mm(H)
Maximum package size: 550 mm(W) x 750 mm(H)
- Larger arches on request

TECHNICAL DATA

Strap Width: 8 mm-12 mm
 Strap Tension: 7 kg to 70 kg
 Speed: 29 straps/minute (60Hz)
 Net Weight: 300 kg
 Power: 110V, 220V, 230V, 380V, 400V
 50/60Hz 1PH or 3PH

Side-Seal Fully-Auto Strapping Machine

Tauris Transit



TP-601YA

- Painted steel frame
- Ideal for dirty strapping environment, such as sawmill plants, brick and tile industries

Options

- ▶ Siemens PLC control
- ▶ Without adjustable roller table (TP-601YA-XT)

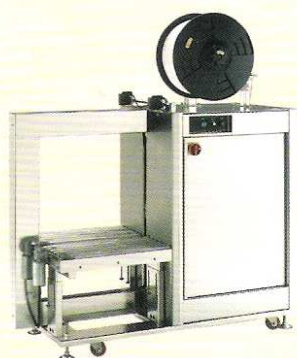

TP-601YAS

- Stainless steel frame SUS 304 and selected parts in stainless steel
- Ideal for moist strapping environment, such as meat, fish, poultry and agricultural processing plants

Options

- ▶ Siemens PLC control
- ▶ Without adjustable roller table (TP-601YAS-XT)

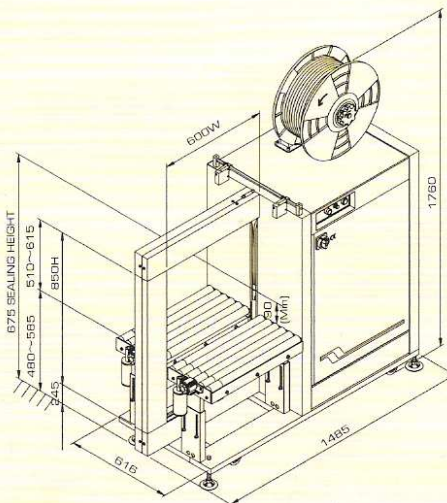

Wash Down Machine



TP-601YAM

- Stainless steel frame SUS 304 with rust resistant and corrosion retardant parts.
- Ideal for moist and harsh strapping environments, exclusively designed for marine food industry.
- Waterproof design to protect the machine from water and wash down spray
- Special protection for the electric control unit to ensure highest safety

Options

- ▶ Siemens PLC control
- ▶ Without adjustable roller table (TP-601YAM-XT)

Main Features:

- ▶ Fully-Auto side-seal strapping machine offers reliability and high performance
- ▶ Multiple strap function for single, double, continuous strapping or transit mode
- ▶ Variable conveyor speed: 10-40 meters/minute
Conveyor minimum height: 480 mm
- ▶ Easy adjustable roller-driven table height
- ▶ Auto strap feeding
- ▶ Electronic tension control
- ▶ Auto strap ejector
- ▶ Larger arch sizes are available for large packages

Arch Sizes:

H \ W	400	600	800	1000
650				
850		Ⓢ		
1050				
1250				

- Standard size: 600 mm(W) x 850 mm(H)
Maximum package size: 550 mm(W) x 565 mm(H)
- Larger arches on request

TECHNICAL DATA

Strap Width: 8 mm-12 mm
 Strap Tension: 7 kg to 70 kg
 Speed: 29 straps/minute (60Hz)
 Net Weight: 330 kg
 Power: 220V, 380V, 400V 50/60Hz 3PH